

## SWISSLOG SPECIFICATIONS

### PICKRING ASSEMBLED 24-HOUR PATIENT-SPECIFIC MEDICATIONS

PickRing creates a 24-hour supply of barcoded patient-specific medications, assembled on a patented, flexible ring—ready for bedside verification.

PickRing significantly reduces missing medications, while emptied bags on the ring provide a physical record of previously administered medications.



PickRings can be configured for multiple order types: patient-specific orders such as first dose, PRN, STAT, cart fill, as well as cabinet replenishment.

The information contained on the PickRing label is flexible allowing medications to be assembled alphabetically by drug name or sequenced by administration time. Each PickRing includes a barcoded tag listing patient information, as well as the ability to include or exclude listing medications that are not contained on the ring.



### Operation

Medication orders along with additional information, e.g. patient name, ID number, room number, drug, dose and administration time, are automatically dispensed from the storage module (DrugNest) and assembled onto the plastic ring.

The PickRings can be transported to nursing units in cassette drawers, carts, or by pneumatic tube systems.

**swisslog**

## PickRing Component



## PickRing Specifications

**Power Requirements:** 460 volt, 3 phase, 1 kW  
**Compressed Air:** 2 CFM @ 90 psi  
**Weight:** 618 lbs (280 Kg)

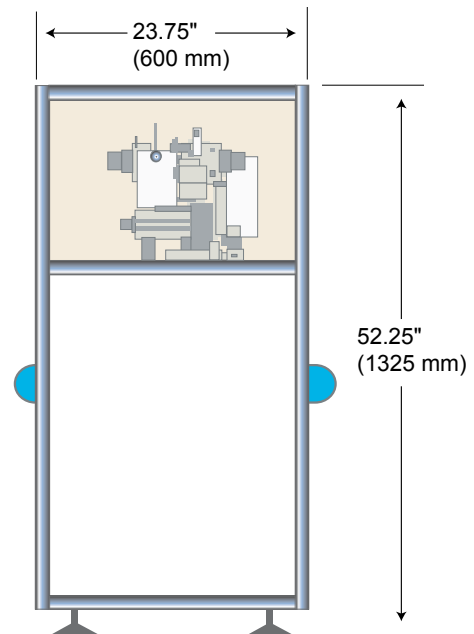
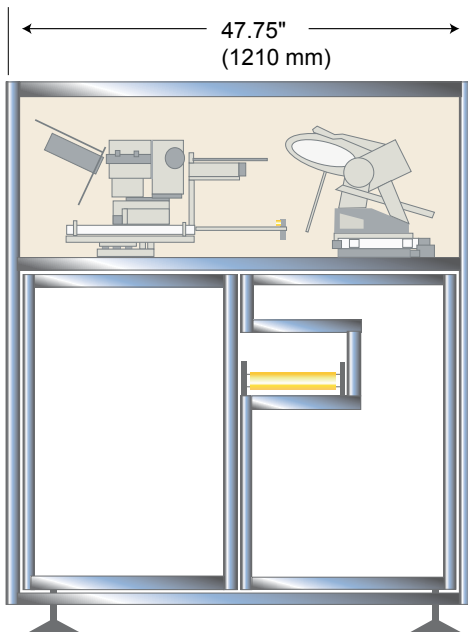

## Ring Specifications

**Material:** PVC  
**Approx. Diameter:** 2" (51 mm)

*Due to ongoing improvement programs, Swisslog reserves the right of production or design change without notice or obligation.*

### For More Information in North America:

Swisslog Healthcare Solutions  
Email: [healthcare@swisslog.com](mailto:healthcare@swisslog.com)  
USA: (800) 764-0300  
Canada: (877) 294-2831 | (905) 629-2400

©2010 Swisslog  
CM# PPS-205

[WWW.SWISSLOG.COM](http://WWW.SWISSLOG.COM)