

SWISSLOG SPECIFICATIONS

BOXSTATION COMPONENT FOR AUTOMATED MEDICATION PACKAGING

BoxStation is a workstation for preparing all medications for packaging, storage and dispensing.

Password protected access, tamper-proof patented canisters, barcode scanning of manufacturer packaging, and radio frequency (RF) technology provide ultimate accuracy and patient safety.



Operation

Solids – Pills, Capsules and Tablets

The operator places a canister (PillBox) into a recess on the top of the BoxStation and presses the OPEN button. This unlocks the tamper-resistant PillBox for the loading of medications. The medication information is entered either at the keyboard or by scanning a barcode label on the original supplier's container. The operator fills the PillBox and replaces the PillBox lid. The lid automatically locks and the medication information is written to the RF tag on the PillBox. The medication is now ready for Pharmacist check and automated packaging.

Over-Wrapping – Vials, Cups, Syringes, Ampoules and Blisters

The operator places a canister (PhialBox) on the pad on the BoxStation and presses the OPEN button on the touch screen. This unlocks the tamper-resistant PhialBox for the loading of medications requiring over-wrap. The operator loads the PhialBox and replaces the lid. The lid automatically locks and the medication information is written to the RF tag on the PhialBox. The medication is now ready for Pharmacist check and automated packaging.

RF Tag Information

The RF tag on the PillBox and PhialBox contain the following information: brand name, generic name, strength, form, identification code, lot number, expiration date, operator identification code, internal mask identification code, date of the last loading process and quantity of items in the PillBox/PhialBox.

swisslog

BoxStation, PillBox and PhialBox Specifications



BoxStation

Power Requirements: 115 volt, single phase, 8 amp
Compressed Air: 1 CFM @ 75 psi
Weight: 110 lbs (50 Kg)

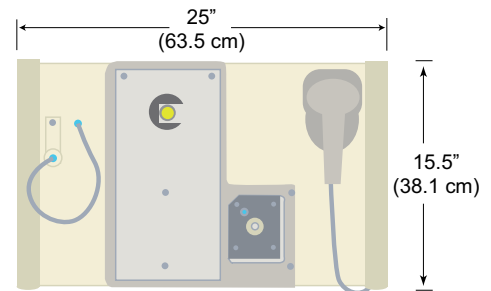
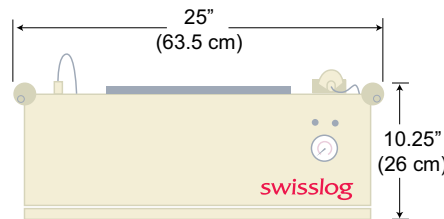

PillBox

Material: Polycarbonate
Weight: 20 oz. (567 g)
Volume: 5254 cc
RF Tag: 500 characters
Capacity (avg. tablet): 500

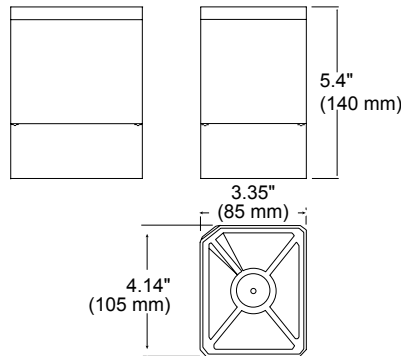

PhialBox

Material: Polyester
Weight: 13 oz. (369 g)
Volume: 775 cc
RF Tag: 500 characters

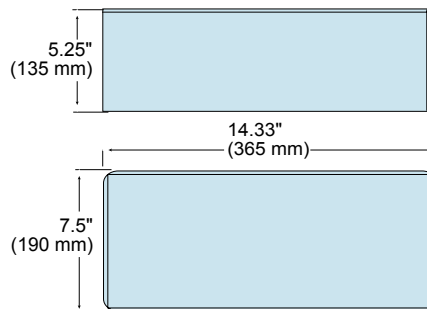

Due to ongoing improvement programs, Swisslog reserves the right of production or design change without notice or obligation.

For More Information in North America:

Swisslog Healthcare Solutions
 Email: healthcare@swisslog.com
 USA: (800) 764-0300
 Canada: (877) 294-2831 | (905) 629-2400

©2010 Swisslog
 CM# PPS-201

WWW.SWISSLOG.COM